

# NEROLI SERIES

## NEROLI-ROUND | FW-BSW



**SEGASiT** ©

The leading Turkish brand of quality Auditorium, Theatre and Cinema Seating



*NEROLI series are manufactured in accordance with the needs of conference and theater halls and in ergonomic designs targeting comfort that fits the audience perfectly.*

*NEROLI-Round | FW-BSW series is in line with the needs of the investor and the audience; It is enriched with a central leg, fabric or leather upholstery, backrest and seat unit wooden cover.*

*The combination of design and comfort makes the series the ideal choice to equip Auditorium and Theater Halls, Conference and Convention Centers, Performing Arts Centers, Corporate and Public Building Halls, and Education-School Halls.*



## DIMENSIONS (mm)

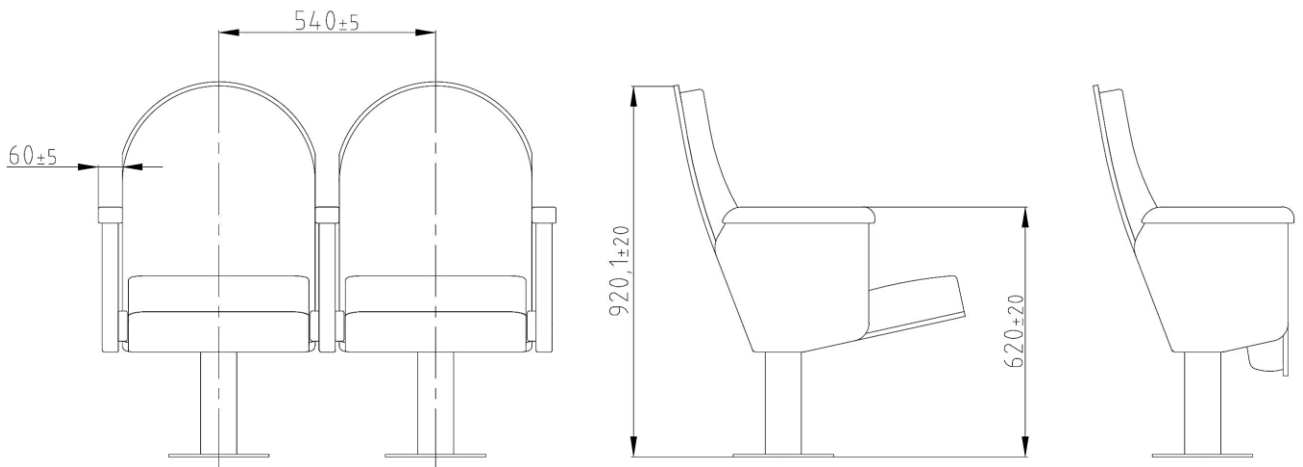

## CHARACTERISTIC FEATURES

- (FW) The lateral armrest fully upholstered, finished with solid wooden armrest unit.
- (BSW) Both backrest and seat paddings are supported with varnished beech plywood backboard.

### NEROLI-Round | FW-BSW

#### Dimensions

- Centre-to-Centre dimension is 54 cm.
- The nominal space for user is 48 cm.

#### Seat and Backrest units

- All paddings are produced with cold moulded CMHR polyurethane foam technology,
- Both backrest and seat padding has a carefully crafted ergonomic design, density 50-60 kg/m<sup>3</sup>.
- Upholstered with padded cover, removable by means of a zipper.
- The seat padding is single block of moulded polyurethane foam that incorporates internal metal frame structure.
- The backrest padding is single block of moulded polyurethane foam that incorporates internal metal frame structure which, due to their shape and composition, offers great back and lumbar support.
- The fully upholstered backrest and seat paddings are incorporated with 12 mm thick varnished beech plywood backboard, the seat backboard is perforated to improve the acoustical absorption.
- Tip-up seat folds automatically with inside weight balance system. Totally silent and maintenance free.

#### Armrests

- Fixed and shared armrest with a curved design.
- Made of 20 mm thick varnished beech solid wooden.
- Decorative lateral panels made of MDF board and upholstered with padded covers.

#### Structure

- The central leg made of square shape 100\*40\*2 mm steel metal profile structure designed and produced to provide durability and long life.
- The central leg is joined to a 6 mm thick steel base and fixed to the floor using metric screws or other suitable type of anchorage for each type of surface.
- The metal parts are painted electrostatic powder paint. Coat thickness 80 micron ± 10.
- The fully upholstered backrest padding is fixed to a metal structure, which is joined to the lateral legs with a concealed insertion system provided strong durability.
- The system is very resistant and ensures the perfect alignment of the backrests when forming a row.

#### Options

- Seat, row numbering and logo embroidery.
- Variety of foam density.
- Variety of fabrics with abrasion, fading and non-flammability characteristics.
- Variety of high quality faux and genuine leather.

#### CERTIFIED PRODUCTION

In our production plant we have implemented the quality management system ISO 9001:2015, the environmental management systems ISO 14001:2015, the safety management system OHSAS 18001:2007 are standard.

This brochure supersedes and replaces all previous issues.

All designs, images and illustrations contained within this brochure remain the copyright of SEGASit.

All trademarks, product names and codes detailed within this brochure are the property of SEGASit.

**SEGASit** ©

[www.segasit.com](http://www.segasit.com)