

RETRO-WT|F

SERIES



SEGASIT ©

The leading Turkish brand of quality Auditorium, Theatre, and Cinema Seating

www.segasit.com



RETRO-WT | F series is in line with the needs of the investor and the audience;

- *It is equipped with an anti-panic writing tablet with a mechanism that provides strong durability.*

It is enriched with

- *lateral legs,*
- *fabric or leather upholstery,*
- *backrest and seat unit wooden covers.*



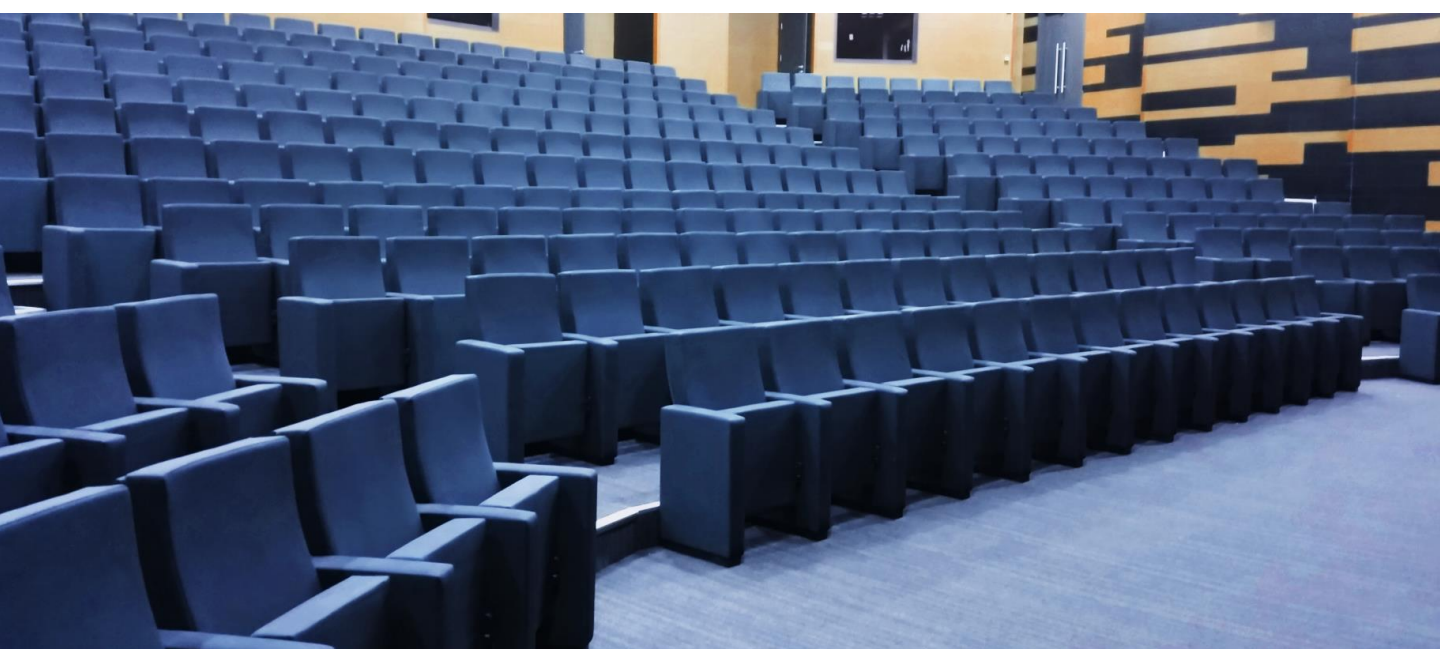

OPTION FEATURES

RETRO-WT | F-BSF

- (F) The lateral feet are fully upholstered with a padded cover.
- (BSF) Both backrest and seat padding are fully upholstered with padded cover.



RETRO-WT | FW-BSF

- (FW) The lateral feet are fully upholstered and finished with a solid wooden armrest unit.
- (BSF) Both backrest and seat padding are fully upholstered with padded cover.



RETRO-WT | FW-BW

- (FW) The lateral feet are fully upholstered and finished with a solid wooden armrest unit.
- (BW) The backrest padding is supported by a varnished beech plywood backboard.



RETRO-WT | FW-BSW

- (FW) The lateral feet are fully upholstered and finished with a solid wooden armrest unit.
- (BSW) Both backrest and seat padding are supported by a varnished beech plywood backboard.



DIMENSIONS (mm)

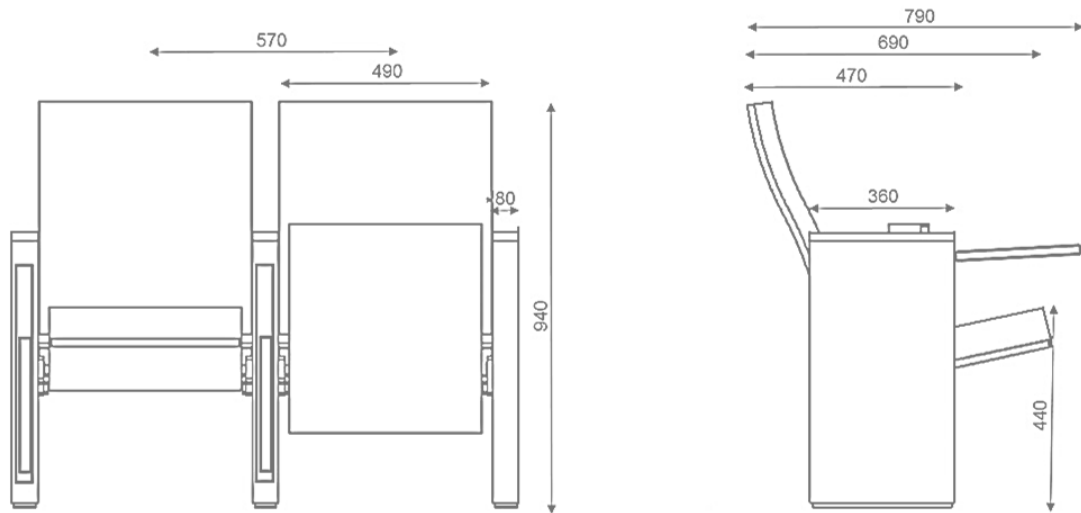

CHARACTERISTIC FEATURES

Dimensions

- Centre-to-Centre dimension is 57 cm.
- The nominal space for the user is 49 cm.

Seat and Backrest units

- All paddings are produced with cold-molded CMHR polyurethane foam technology,
- Both backrest and seat padding has a carefully crafted ergonomic design, density of 50-60 kg/m³.
- The seat padding is a single block of molded polyurethane foam that incorporates an internal metal frame structure, plus supported with an internal flat springs structure to provide sitting comfort long time.
- The backrest is made of beech plywood, incorporating fully upholstered, open-cell polyurethane foam cushions which, due to their shape and composition, offer great back and lumbar support.
- Upholstered with a padded cover, removable by means of a zipper.
- Tip-up seat folds automatically with an inside weight balance system. Totally silent and maintenance-free.

Optional

- **Controlled Slow Rising System** by means of silent, controlled slow movement with no bumps.
- The seat folds up automatically with controlled slow movement by a pneumatic piston mechanism located at the side panel. Totally silent and maintenance-free.

Armrests

- Fixed and shared armrest box in ergonomic design.
- Fully upholstered with a padded cover.
- Equipped with an anti-panic varnished beech plywood writing tablet with a mechanism that provided strong durability.
- Optional, wooden armrest made of 20mm thick varnished solid wood

Structure

- The lateral feet are made of a 12 mm thick MDF box designed and produced to provide durability and long life.
- The lateral legs are fully upholstered with padded covers.
- The lateral legs are joined to a steel base and fixed to the floor using metric screws or other suitable types of anchorage for each type of surface.
- The beech plywood backboard, incorporated with fully upholstered foam cushions, is fixed to the lateral legs with a concealed metal slide insertion system that provides strong durability.
- The system is very resistant and ensures the perfect alignment of the backrests when forming a row.
- The metal parts are painted with electrostatic powder paint. Coat thickness 80 microns \pm 10.

Options

- Side-mounted anti-panic foldaway writing tablet.
- Backrest cover: Beech plywood.
- Seat back cover: Beech plywood perforated.
- Seat, row numbering, and logo embroidery.
- Variety of foam density.
- Variety of fabric with abrasion, fading, and non-flammability characteristics.
- Variety of high-quality faux and genuine leather.

CERTIFIED PRODUCTION

In our production plant, we have implemented the quality management system ISO 9001:2015, the environmental management systems ISO 14001:2015, and the safety management system OHSAS 18001:2007 are standard.

SEGASit ©

www.segasit.com